

Dehler  **38 SQ**





A TRUE DEHLER – SPEED MEETS QUALITY

– **SEIT 1963** werden bei Dehler kontinuierlich Segelyachten entwickelt, die den Inbegriff des Performance Cruisers und der Innovationskraft verkörpern. Diese Kontinuität erlebt nun ihre nächste Fortsetzung. Mit einer Yacht, die ihre Tradition bereits im Namen trägt: die Dehler 38SQ.

– **SINCE 1963**, Dehler has been developing sailing yachts that epitomise performance cruising and the power of innovation. This continuous quest for excellence has resulted in yet another leap forward. It is a yacht that carries the founding principles in its very name: the Dehler 38SQ.

PROCEED WITH SPEED – SMART PERFECTION – GERMAN ENGINEERING

Dehler  **38 SQ**

DETAILS MAKE THE DIFFERENCE

Performance Cruiser – neuester Stand. In allen Bereichen punktet die Dehler 385Q mit smarten Weiterentwicklungen: bei Komfort, Qualität und Performance. Für ein gesteigertes Segelerlebnis vom ersten bis zum letzten Moment.

State of the art performance cruiser. With smart new developments, the Dehler 385Q scores in all areas: comfort, quality and performance. For an enhanced sailing experience from the first to the last moment.



◁ **Klare, markante Linien,** progressives Design und beeindruckende Dynamik.

The yacht's sharp, distinctive lines reflect her progressive design and impressive dynamics.

Wählen Sie **High-Performance Squaretop-Segel** für mehr Effizienz und weniger Krängung.

Choose **high-performance squaretop sails** to increase efficiency and reduce heel.



▷ **Zusätzliche Fenster** im Aufbau sorgen für helles Tageslicht.

Additional windows in the coach-roof bring in lots of natural light.

▷ **Der feste Bugspriet** mit integriertem Ankerarm verlagert den Anschlagpunkt für Gennaker und Dehler Freeride nach vorn.

The fixed bowsprit with built-in anchor arm puts the tack point for a gennaker or Dehler Freeride even further forward.



▷ **Ausklappbare Fußstützen,** bündig im Cockpitboden eingelassen, ermöglichen einen besonders komfortablen Stand.

Retractable footrests, flush-mounted into the cockpit sole, allow an especially comfortable footing on the heel.





STIRRING PERFORMANCE TURBO CHARGED

— **Nehmen Sie die sportliche Herausforderung an.** Verleihen Sie Ihrer Dehler 385Q das Extra an Dynamik und trimmen Sie die Yacht auf maximale Segelleistung: mit Karbon-Rigg, Squaretop-Membransegeln, verlängertem Bugsprit und Racing-Winschen.

— **Take on the sporting challenge.** Give your Dehler 385Q that extra bit of dynamism and trim the yacht for maximum sailing performance. Select carbon rigging, squaretop membrane sails, extended bowsprit and racing winches.



EFFORTLESS CRUISING. LAID-BACK MOOD.

_ Lassen Sie sich vom Seewind tragen. Die Brise und die Dehler 38SQ erledigen die ganze Arbeit für Sie. Schoten und Fallen laufen direkt zum Steuerstand, alles liegt perfekt zur Hand. So wird der Segeltrimm zum lässigen Freizeitvergnügen.

_ Let the sea breeze carry you. The wind and the Dehler 38SQ do all the work for you. Sheets and halyards run directly to the helm, putting everything within reach. Sail handling becomes truly relaxing.





ON THE HOOK IN THE LAP OF LUXURY

— **Wenn Sie Ihren Ankerplatz erreicht haben,** begeistert Sie die Dehler 38SQ noch lange weiter. Das Cockpit bietet viel Platz zum Entspannen – und jederzeit die passende Atmosphäre. In den vollflächigen Teakboden ist als Ambientebeleuchtung ein umlaufendes LED-Lichtband eingelassen.

— **Once you have reached your anchorage,** the Dehler 38SQ will continue to inspire you. The cockpit offers plenty of space to relax – and the perfect atmosphere at any time. The full teak decking is enhanced with an all-round LED light strip for ambient lighting.





— Lassen Sie die Seele Urlaub machen. Die Badeplattform mit Handlauf und bündig eingelassener Badeleiter ist der perfekte Ort dafür. Auf den großen, komfortablen Cockpitbänken feiern Sie den Ausklang eines unvergesslichen Tages.

— Let your soul take a holiday. The bathing platform with handrail and flush-mounted bathing ladder is the perfect place for it. Celebrate the end of an unforgettable day on the large, comfortable cockpit benches.



SUPREME COMFORT. FLAWLESSLY FINISHED.

— **Ein Cockpit für Segel-Enthusiasten.** Hier stimmt alles: Von Sport-Steuerrädern mit Y-Speichen bis zum bündig integrierten Traveller. Das gesamte Cockpit liegt auf einer Ebene, mit freiem Durchgang zur Badeplattform. Die Duchten gehen fließend in die abgerundeten Instrumentenkonsolen über, was die Bänke spürbar verlängert.

— **A cockpit for sailing enthusiasts.** Everything is just so: from sports steering wheels with Y-spokes to the flush-mounted traveller. The entire cockpit is on a single level, with free access to the bathing platform. The cockpit coaming flows smoothly into the rounded instrument consoles, which noticeably lengthen the benches.



EVERY LINE WORKS IN HARMONY

— **Magnetische Anziehungskraft** aus jedem Blickwinkel. Klarere Linien. Sportlichere Optik. Markantere Rumpffenster – und ein perfekt in die Linienführung integrierter Bugspriet. Der neu gestaltete Aufbau bietet ein Salonfenster mehr auf jeder Seite.

— **Magnetic attraction** from every angle. Cleaner lines. A sportier look. More striking hull windows - and a bowsprit perfectly integrated into the deckline. The newly designed coachroof now offers an extra saloon window on each side.





CLASS TAKES MANY FORMS. HERE ARE THREE.

STANDARD

MAST HEIGHT ABOVE WL
17.70m / 58'1"

MAINSAIL
43.00m² / 463sq ft

JIB (105 %)
35.60m² / 383sq ft

TOTAL SAIL AREA
78.60m² / 846sq ft

RIG

Standard
I 15.07m / 49'5"
J 4.36m / 14'4"
P 14.50m / 47'7"
E 5.20m / 17'1"

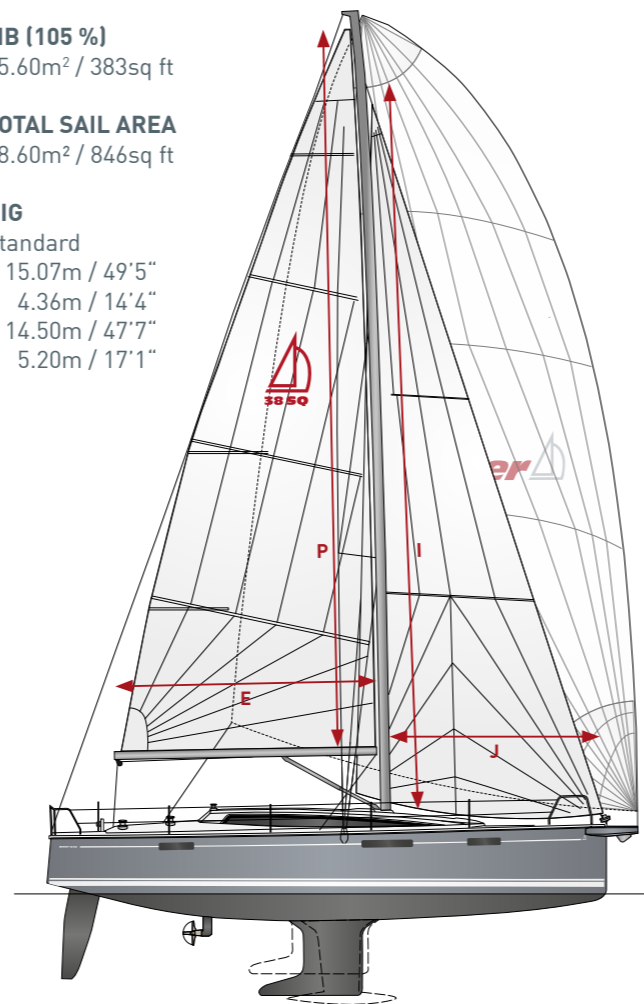

COMPETITION ALU

MAST HEIGHT ABOVE WL
17.70m / 58'1"

MAINSAIL
48.00m² / 517sq ft

JIB (105 %)
35.60m² / 383sq ft

TOTAL SAIL AREA
83.60m² / 900sq ft

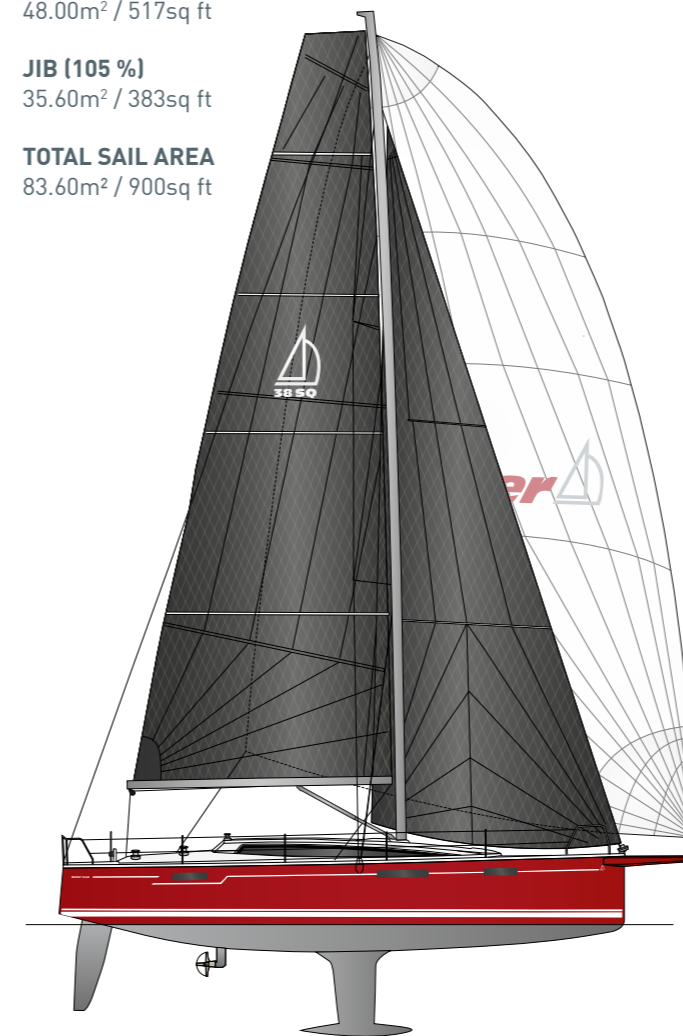

COMPETITION CARBON

MAST HEIGHT ABOVE WL
17.80m / 58'5"

MAINSAIL
49.00m² / 527sq ft

JIB (105 %)
35.60m² / 383sq ft

TOTAL SAIL AREA
84.60m² / 911sq ft



HULL

LOA 12.07m / 39'7"
Hull length 11.30m / 37'1"
LWL 10.40m / 34'1"
Beam 3.75m / 12'4"

DRAUGHT

Standard 2.03m / 6'8"
Competition 2.24m / 7'5"
Shallow 1.60m / 5'3"

DISPLACEMENT

Standard 7.50t / 16,534lbs
Competition 7.00t / 15,432lbs
Shallow 7.60t / 16,755lbs

BALLAST

Standard 2.38t / 5,247lbs
Competition 2.05t / 4,508lbs
Shallow 2.75t / 6,062lbs

ENGINE

Diesel 29PS / hp

TANKS

Fresh water 295l / 77.93gal
Fuel tank 160l / 42.27gal

HULL DESIGN

judel / vrolijk & co

CE CERTIFICATE

A - 6 / B - 10

SPINNAKER

competition 101.70m² / 1,095sq ft

GENNAKER

standard 103.70m² / 1,116sq ft
competition 121.00m² / 1,302sq ft

DEHLER FREERIDE

82.10m² / 884sq ft



AN AMBIENCE SHAPED BY ELEGANCE

— Eine Hommage an das Licht. Helligkeit charakterisiert das noble Interieur der Dehler 38SQ. Sämtliche Oberflächen tragen zu der freundlichen, sonnigen Atmosphäre bei. Vor allem ein Design-Element wird schon fast verschwenderisch eingesetzt: das natürliche Tageslicht. Spürbar vergrößerte Fensterflächen im Salon und in den Kabinen lassen Sie vergessen, unter Deck zu sein.

— A homage to light. Brightness characterises the noble interior of the Dehler 38SQ. Every surface contributes to the friendly, sunny atmosphere. One design element in particular is lavishly exploited: natural light. Noticeably larger windows in the saloon and cabins make you forget you are below deck.



Dehler  **38 SQ**



SUPERB FABRICS NATURALLY ILLUMINATED

Wohndesign aus einem Guss. Elfenbeinfarben verkleidete Wände harmonieren perfekt mit jedem Möbelstoff. Handläufe in Schwarz addieren einen effektvollen Akzent. Der zweiflügelige Salontisch verbindet beide Sofas – oder lässt eingeklappt den Durchgang zur Bugkabine frei.

Coherent interior design. Off-white walls perfectly match any upholstery fabric. Handrails in black add an effective highlight. The double-leaf saloon table connects both sofas – or, when folded, leaves the way to the forward cabin free.

Die hochwertige Polsterkollektion wurde sorgfältig auf das Interieurdesign abgestimmt.

The first-class collection of upholstery has been carefully matched to the interior design.



oyster

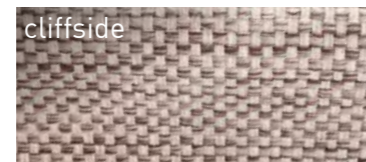

cliffside

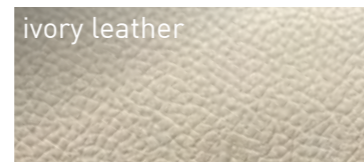

ivory leather

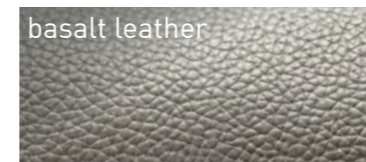

basalt leather



teak

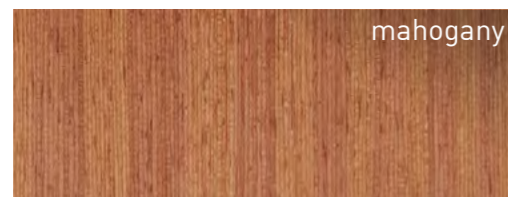

mahogany



oak

Feine Möbelhölzer kommen großflächig zum Einsatz. Jede Variante weist ihre eigenständige Maserung auf.

Fine furniture woods are used extensively. Each variation features its special, characteristic grain.



TIME FOR GREAT CUISINE

— Mit allen Raffinessen genießen. Ein von oben und von vorn erreichbarer Kühlschrank, ein ausziehbares Weinregal im Salontisch: Ihr Wohnbereich steckt voller smarter Details. Der Stauraum reicht für alle kulinarischen Wünsche Ihrer Crew.

— Enjoyment with all the trimmings. A refrigerator with top and side access, a pull-out wine rack in the saloon table: the living area is full of smart details. There is enough storage space for all your crew's culinary desires.



PURE LUXURY BATHED IN LIGHT

Exquisite Ausstattung. Vergrößerte Rumpffenster bringen die Sonne in die Eignerkabine. Indirekte Beleuchtung gibt dem Lichtkonzept den letzten Schliff. Auch das große Designerbad mit separatem Duschbereich verdankt dieser Stilphilosophie sein charmantes Ambiente.

Exquisite fittings. Larger hull windows bring natural light into the owner's cabin. Clever indirect lighting adds the finishing touches. The large designer bathroom with separate shower area also owes its charm to this use of light.

CABIN LAYOUT | STANDARD

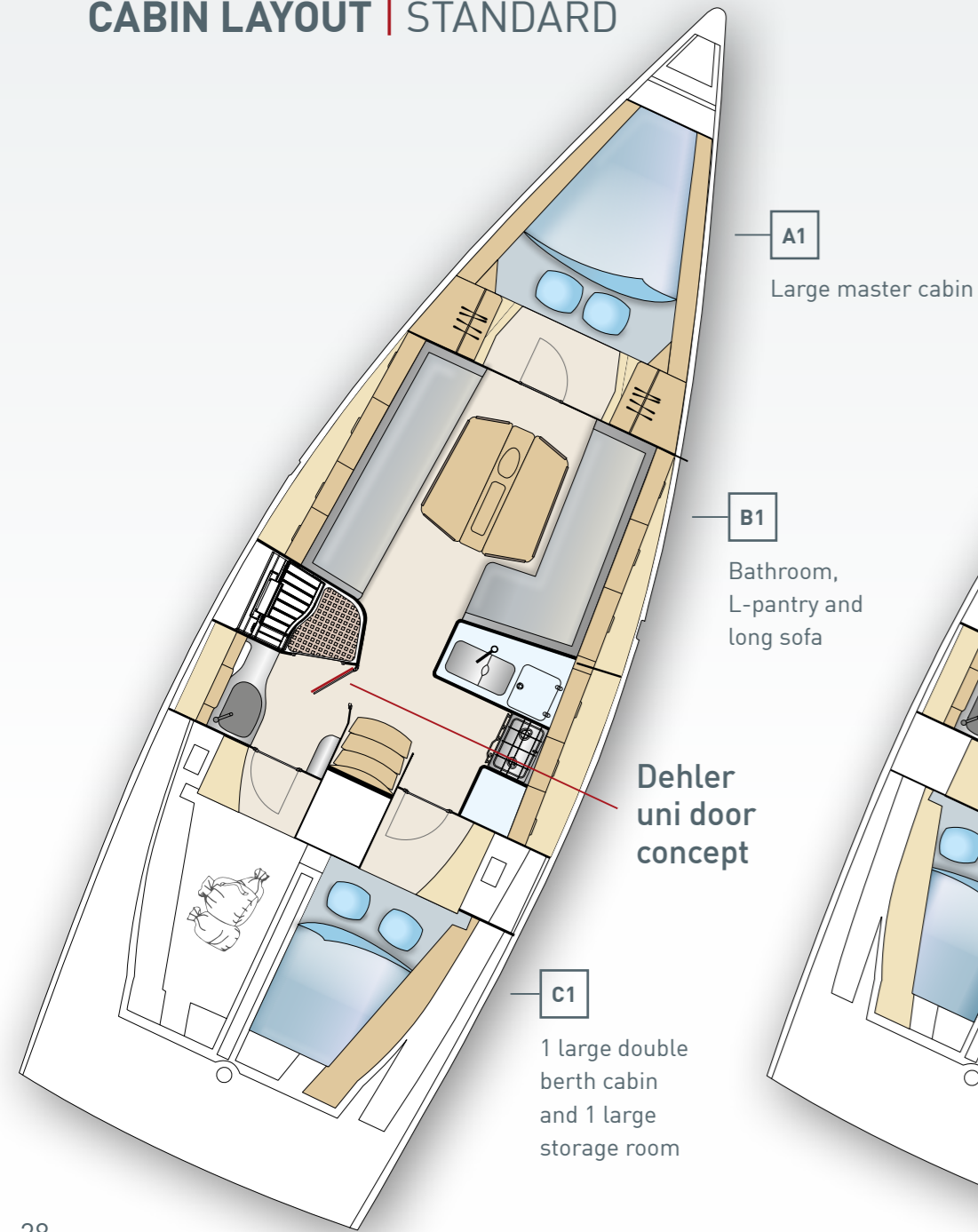

| OPTION

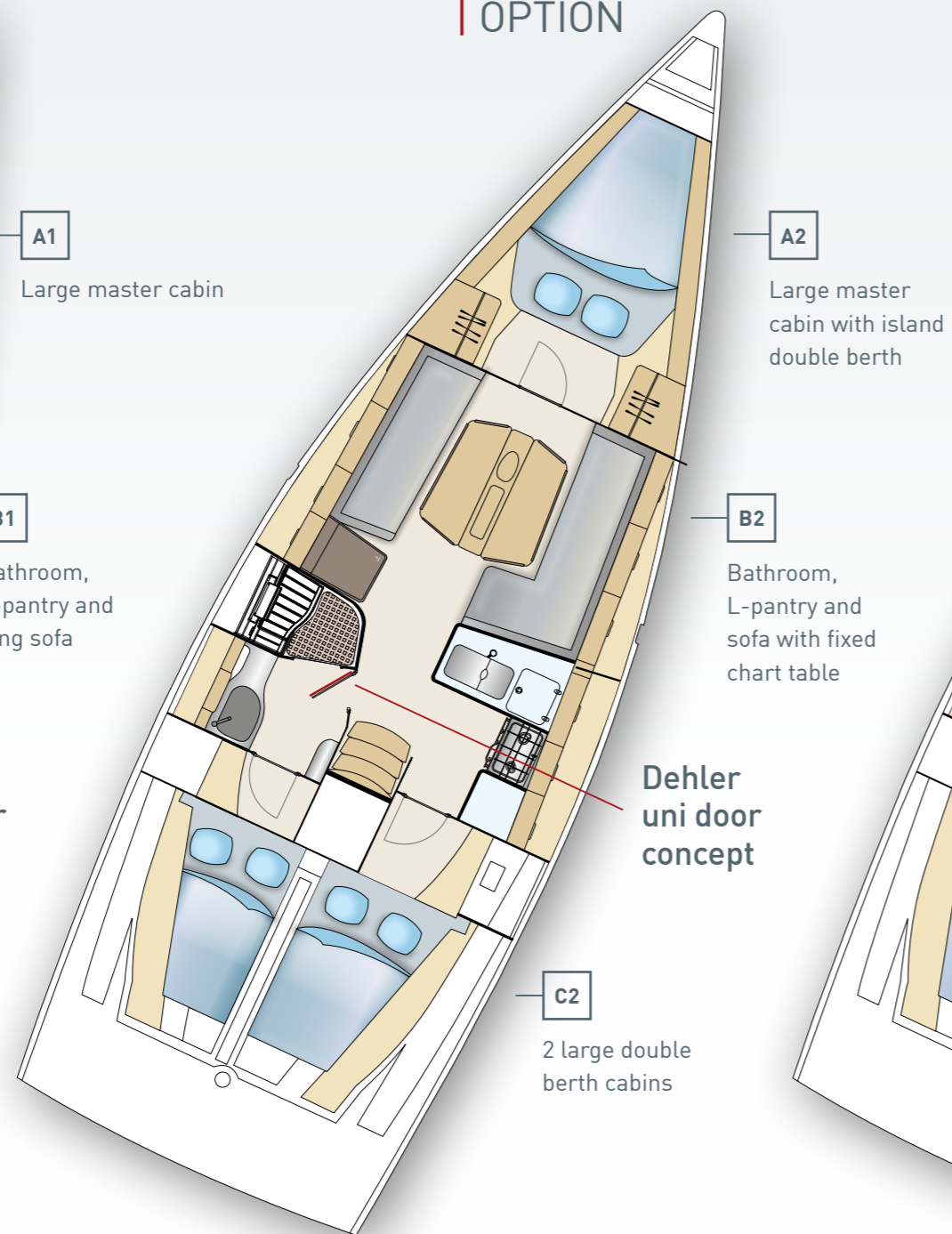

| OPTION

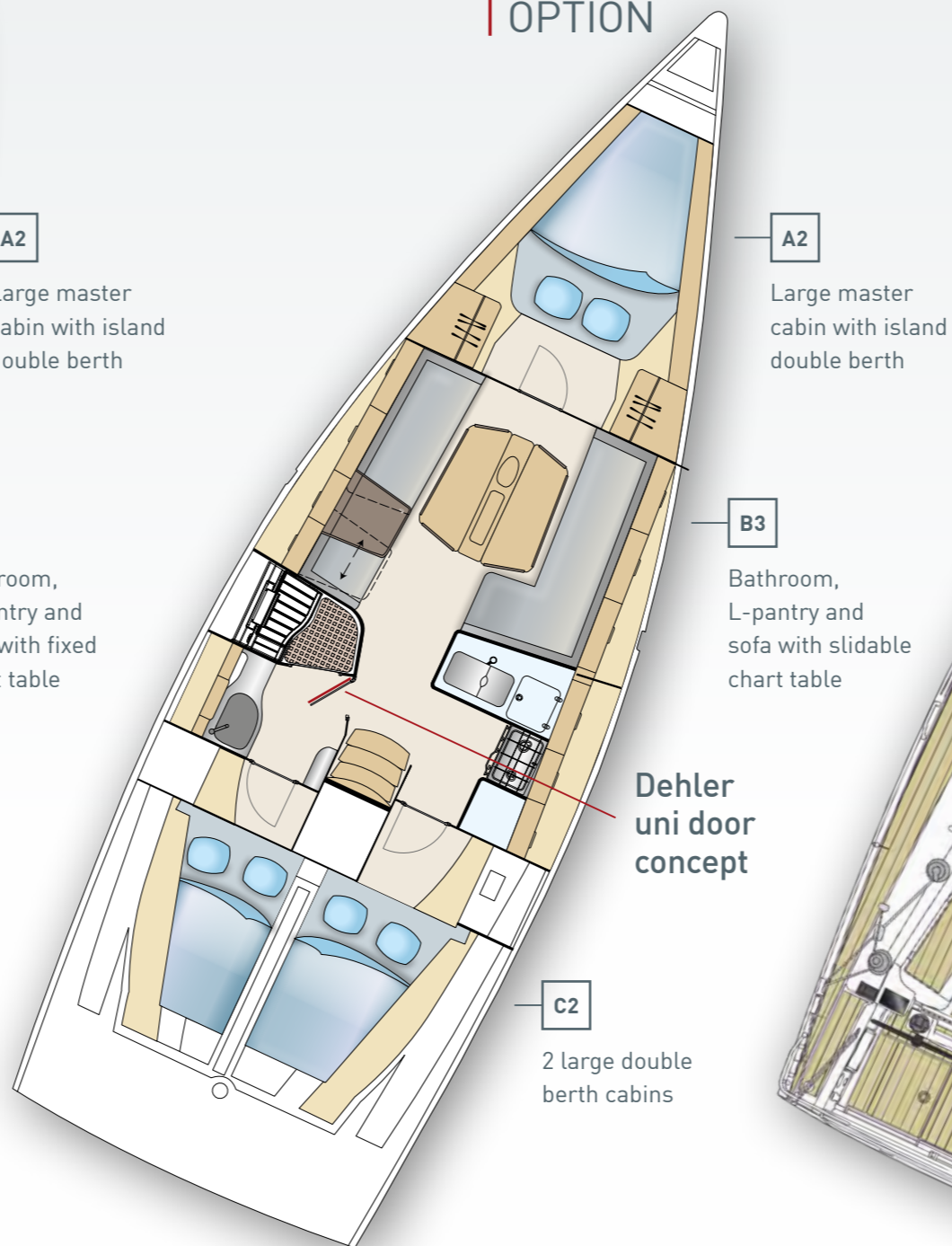

DECK LAYOUT

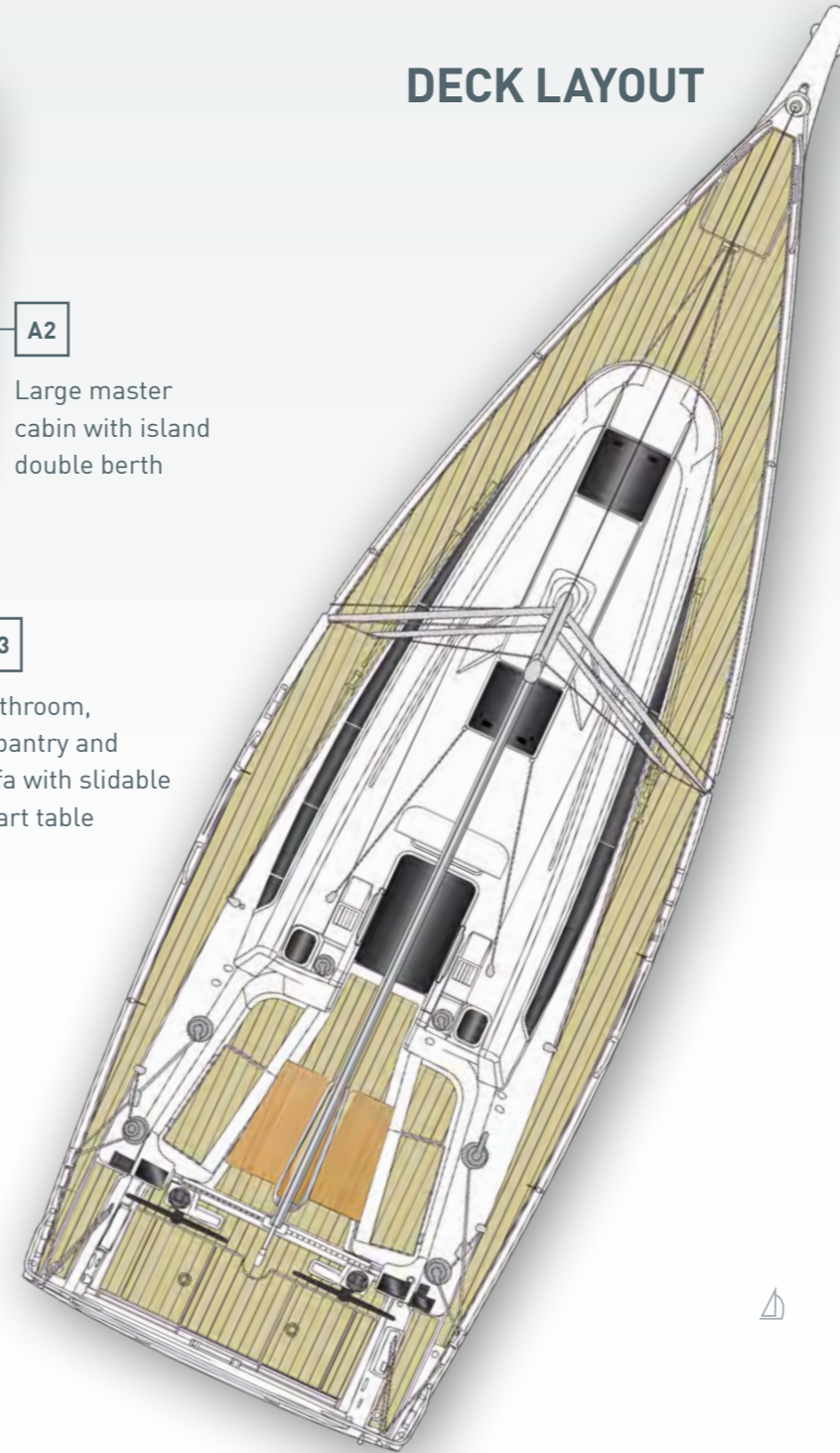

LAYOUT FOR YOUR LIFESTYLE

Wohnerlebnis nach Maß. Ein Navigationstisch im Salon, ein Inselbett für die Eigner oder eine zweite Kabine achtern für Ihre Gäste: Ihre Lebensart entscheidet.

Tailored to your lifestyle. A navigation table in the saloon, an island bed for the owners or a second cabin aft for your guests: your way of life decides.





Dehler  **38 SQ**

ADVANCED ENGINEERING. IN EVERY DETAIL.

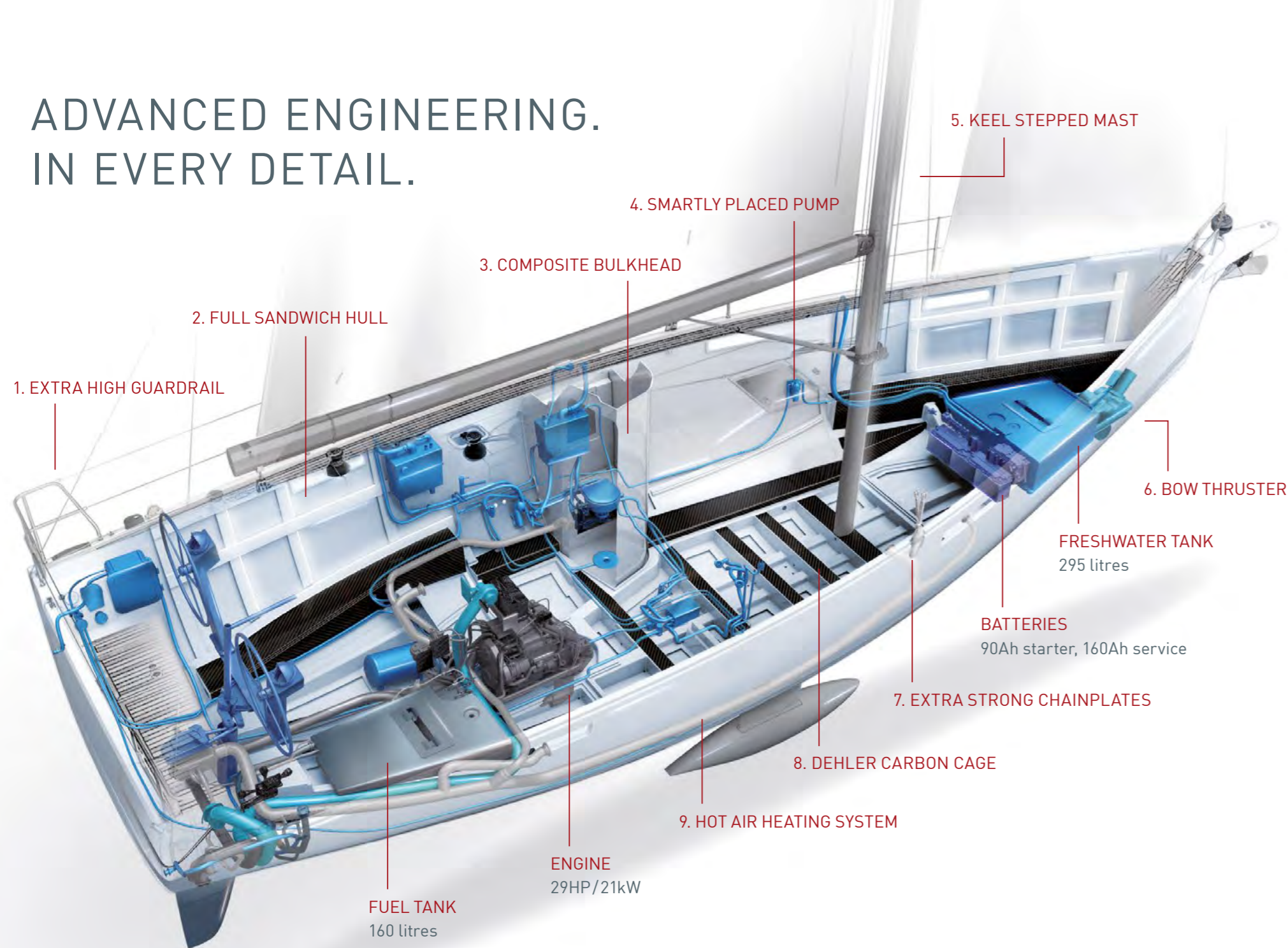

1. EXTRA HIGH GUARDRAIL

2. FULL SANDWICH HULL

3. COMPOSITE BULKHEAD

4. SMARTLY PLACED PUMP

5. KEEL STEPPED MAST

6. BOW THRUSTER

FRESHWATER TANK
295 litres

BATTERIES
90Ah starter, 160Ah service

7. EXTRA STRONG CHAINPLATES

8. DEHLER CARBON CAGE

9. HOT AIR HEATING SYSTEM

ENGINE
29HP/21kW

FUEL TANK
160 litres

1. EXTRA HOHER SEEZAUN
für höchste Sicherheit am Steuer.
EXTRA HIGH GUARDRAIL
for maximum safety at the helm.

2. VOLL SANDWICH RUMPF
Sandwichkern aus Balsaholz mit
wasserdichtem Vinylesterharz lami-
niert. Verwindungssteif und leicht.
FULL SANDWICH HULL
Balsa wood sandwich core laminated
with premium quality vinylester resin -
rigid and lightweight.

3. COMPOSITE SCHOTT
Die Duschkabine ist als separates
Schott konstruiert. Sie integriert
sich nahtlos ins Rumpfdesign und
lässt sich besonders leicht reinigen.
COMPOSITE BULKHEAD
The shower compartment is designed
as a separate bulkhead. It integrates
seamlessly into the hull design and is
particularly easy to clean.

4. GESCHICKT PLATZIERTE PUMPE
Die Frischwasserpumpe ist
geräuschneutral außerhalb der
Kabinen montiert.
SMARTLY PLACED PUMP
To reduce noise, the freshwater pump
is installed outside the cabins.

5. DURCHGESTECKTER MAST
für optimale Kräfteverteilung,
mehr Stabilität, besseren Trimm.
KEEL STEPPED MAST
for optimal distribution of forces,
more stability, better trim.

6. BUGSTRAHLRUDER
bei Bedarf ausfahrbar.
BOW THRUSTER
folds out when needed.

7. EXTRA STARKE PÜTTINGE
Die mit zehn Lagen Glasfaser-
gewebe verstärkten Püttinge
halten enormen Zugkräften stand.
EXTRA STRONG CHAINPLATES
Reinforced with ten layers of glass
fibre, the chainplates can withstand
enormous tensile forces.

8. DEHLER CARBON CAGE
Die Bodengruppe ist an sorgfältig
ausgewählten Bereichen mit Karbon-
fasern verstärkt. So werden die
Torsionskräfte auf hoher See und
bei hoher Riggspannung minimiert,
der Rumpf hält stärkere Wind- und
Wasserkräfte aus.
DEHLER CARBON CAGE
The floor structure is reinforced
with carbon fibre at key stress points.
Torsion in the hull is minimised under
high rig loads and in high seas, enab-
ling it to better withstand the forces
of water and wind.

9. WARMLUFTHEIZUNG
Dieselbetrieben, programmierbar.
HOT-AIR HEATING SYSTEM
Diesel-operated, programmable.

KEEL TYPES

STANDARD KEEL

- | High performance deep fin keel
- | Low centre of gravity
- | Most of the weight is concentrated at the lowest point below the waterline
- | Draught 2.03m
- | Weight 2,380kg



centre of gravity

COMPETITION KEEL

- | A hybrid construction comprising a cast iron fin with a lead bulb
- | Extremely low centre of gravity, leading to highest possible righting moment
- | Narrow fin for reduced drag and higher speed
- | Bulb shape achieves optimum hydrodynamics
- | Perfect ballast distribution for optimal trim in water
- | Draught 2.24m
- | Weight 2,050kg

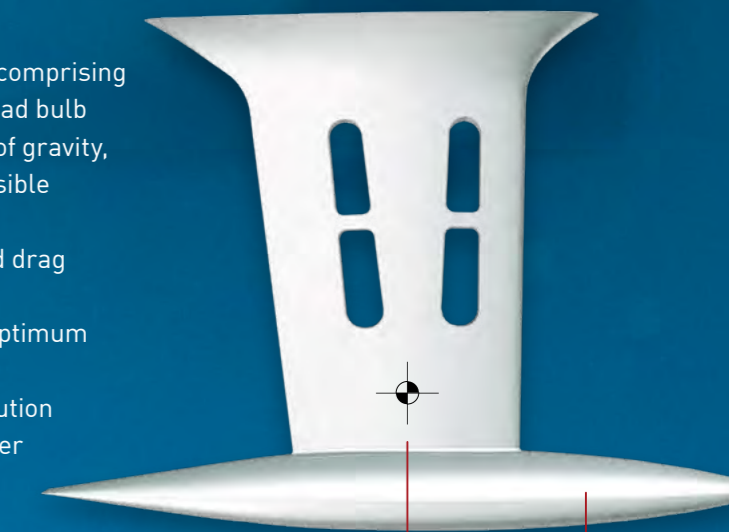

centre of gravity

lead bulb

POWERFUL SAILS FOR PASSIONATE SAILORS

Inspired by the best Seglern, Segelmachern und Designern, sowie umfassenden Daten aus all deren Projekten – von der Superyacht bis zum Dinghy – entwickelte Quantum seine neuen Hightech-Produkte für Dehler-Yachten.

Das Ergebnis: ein individuell gefertigtes Segel, dessen perfekte Form ein kontrolliertes, müheloses und somit souveränes Manövrieren ermöglicht. Für beste Segelerlebnisse. Immer und immer wieder.

Fueled by the best sailors, sailmakers and designers in the world and comprehensive data and insights from every project they've worked on – from superyachts to dinghies – Quantum developed their latest high-tech products for Dehler yachts.

The result is a custom sail engineered to achieve the perfect shapes that, simply put, give you confidence through control and ease of use for the best experience on the water time and time again.

QUANTUM TP6 | HIGH-END MEMBRANE LAYERS

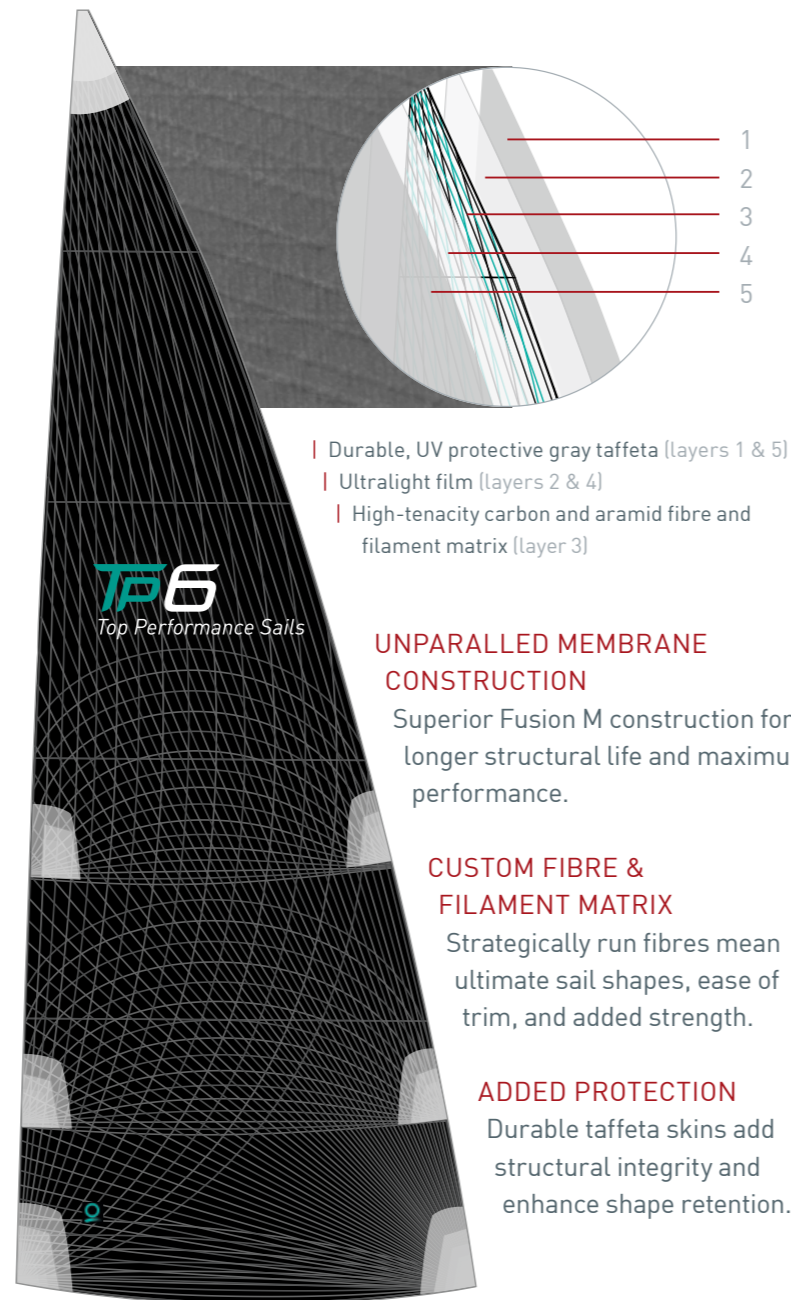

- | Durable, UV protective gray taffeta (layers 1 & 5)
- | Ultralight film (layers 2 & 4)
- | High-tenacity carbon and aramid fibre and filament matrix (layer 3)

UNPARALLED MEMBRANE CONSTRUCTION

Superior Fusion M construction for longer structural life and maximum performance.

CUSTOM FIBRE & FILAMENT MATRIX

Strategically run fibres mean ultimate sail shapes, ease of trim, and added strength.

ADDED PROTECTION

Durable taffeta skins add structural integrity and enhance shape retention.

QUANTUM AC5 | PERFORMANCE LAYERS

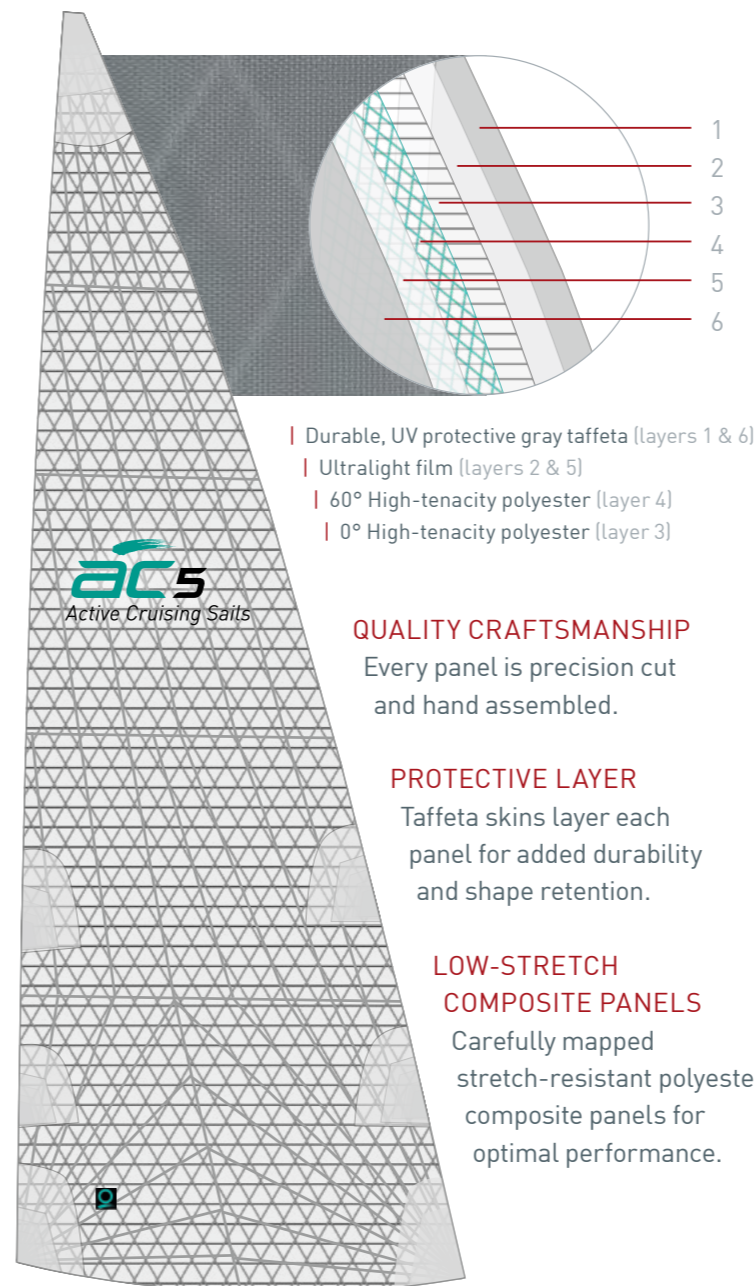

- | Durable, UV protective gray taffeta (layers 1 & 6)
- | Ultralight film (layers 2 & 5)
- | 60° High-tenacity polyester (layer 4)
- | 0° High-tenacity polyester (layer 3)

QUALITY CRAFTSMANSHIP

Every panel is precision cut and hand assembled.

PROTECTIVE LAYER

Taffeta skins layer each panel for added durability and shape retention.

LOW-STRETCH COMPOSITE PANELS

Carefully mapped stretch-resistant polyester composite panels for optimal performance.

DEHLER FREERIDE | 62.80M²

The Dehler **FREERIDE** is the perfect intermediate size between genoa and gennaker, offering the largest wind range in its class. That means, the FREERIDE speeds up your Dehler, no matter if you are sailing a close reach or broad reach course. Fully optimised for single-handed sailing, it is set out of the specially designed sailbag at deck level. Attaching it to the anchor bracket and gennaker halyard takes two simple clicks. The rolled-up sail can remain set as second forestay in the marina. It is operated with the gennaker sheets using any winch in the cockpit.

UV-PROTECTED —

INTEGRATED TORSION CABLE AND ENDLESS FURLING SYSTEM —

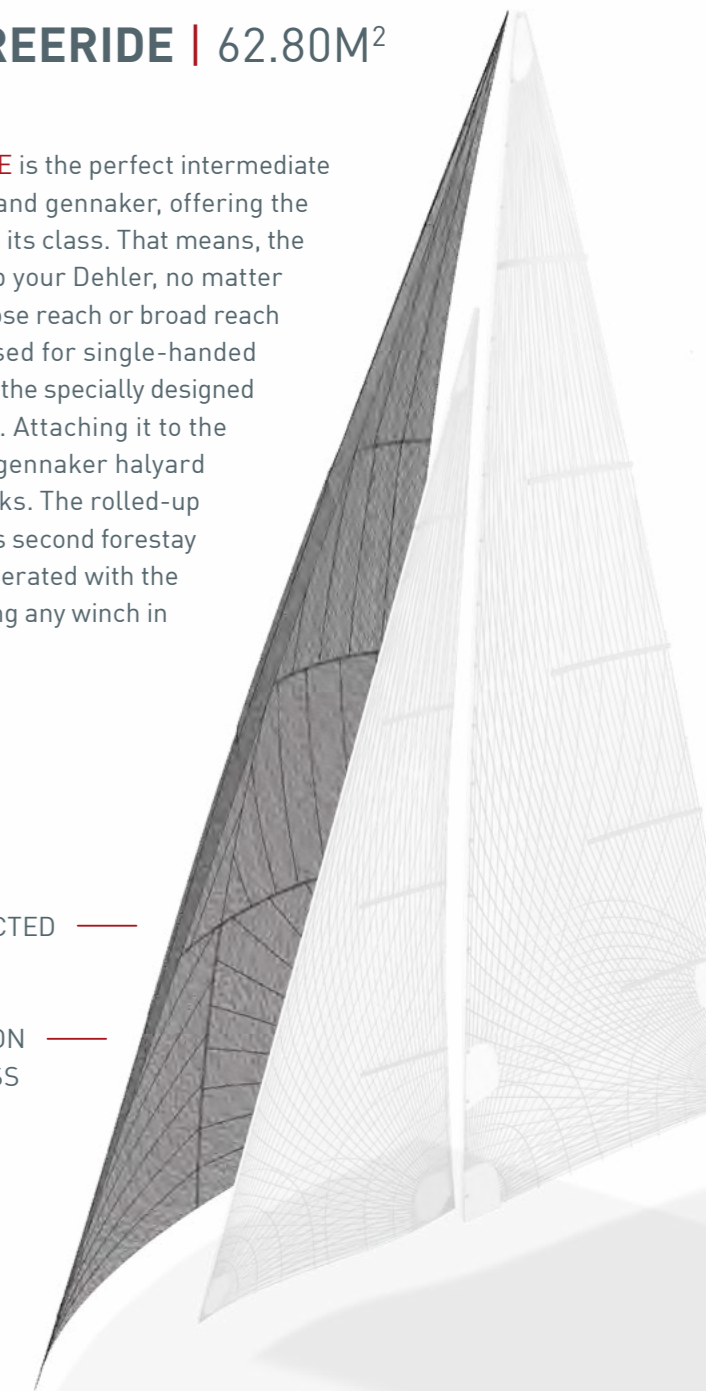



GELCOAT HULL,
WATERLINE & COVELINE



signal white RAL 9003
dark blue RAL 5004



grey RAL 7040
signal white RAL 9003



grey RAL 7040
dark blue RAL 5004

PAINTED HULL,
WATERLINE & COVELINE

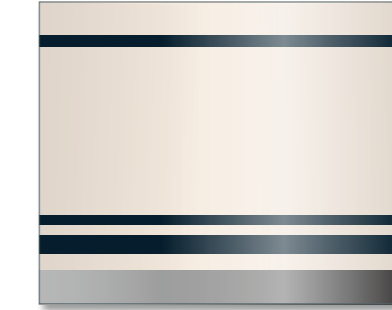

oyster white T 9128
flag blue T 5153



palma blue M 5922 (metallic)
off white T 9130



flag blue T 5153
dark grey T 7156



sunfast red T 3150
off white T 9130



EXTERIOR COLOURS AND MATERIALS

EXPRESSIVE COLOURS AT YOUR COMMAND

_ Setzen Sie mit Ihrer Dehler ein ästhetisches Zeichen. Ihr Händler stellt Ihnen gerne die gesamte Material- und Farbkollektion von Dehler vor.

_ Make a style statement with your Dehler. Your dealer will be happy to show you Dehler's entire upholstery and colour collection.



EXTERIOR | COVERS & UPHOLSTERY

_ **Stoffe in Spitzenqualität** trotzen jedem Wetter. Zeitgemäße, maritime Farben geben dem Erscheinungsbild Ihrer Dehler stilvolle Akzente.

_ **Top-quality fabrics** defy any weather and shape the appearance of your Dehler with contemporary maritime colors.

MAINDROP, SPRAYHOOD, STEERING WHEEL COVER, COCKPIT TABLE COVER OPTIONS

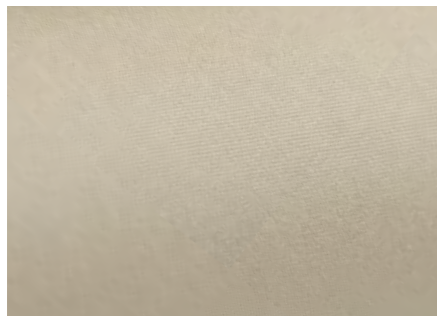

cream



light grey

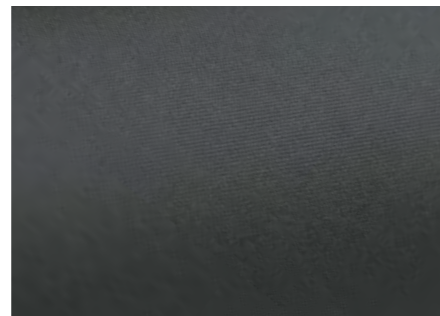

dark grey

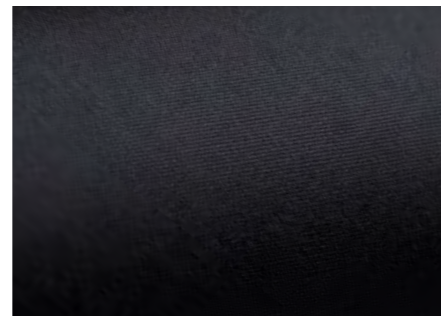

black

COCKPIT CUSHIONS OPTIONS



light grey

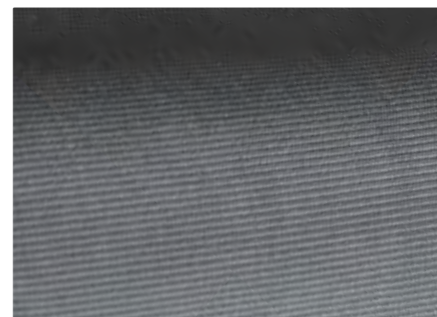

dark grey

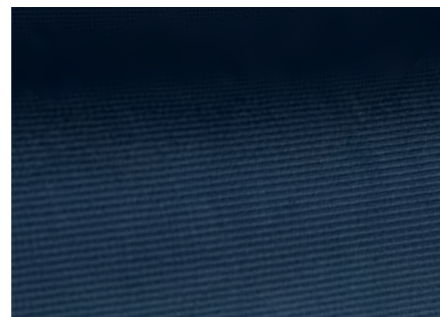

dark blue

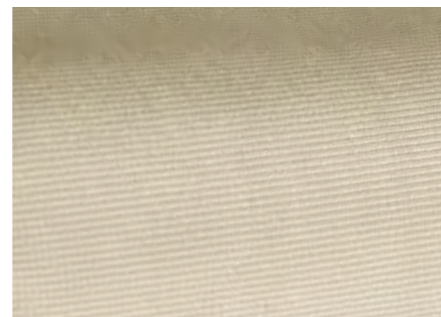

beige

EXTERIOR | NATURAL TEAK & SYNTHETIC TEAK

SYNTHETIC TEAK OPTIONS

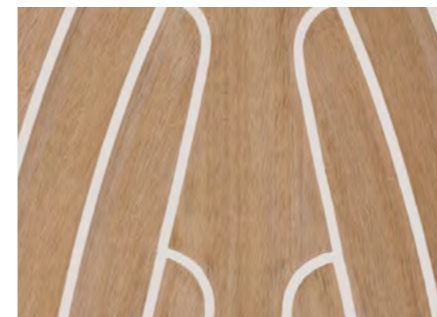

teak look | white caulking

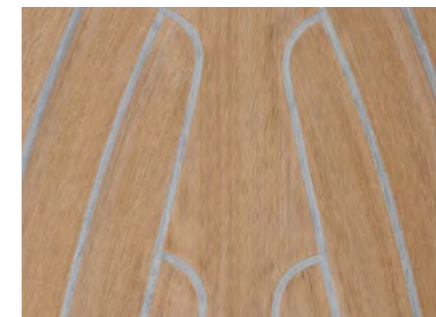

teak look | grey caulking



teak look | black caulking

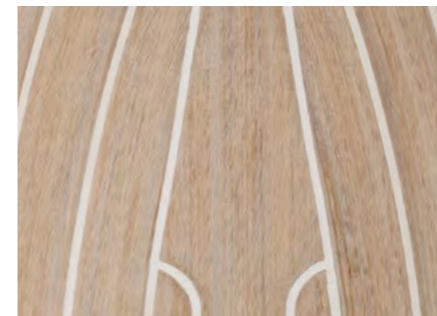

scrubbed look | white caulking



scrubbed look | grey caulking

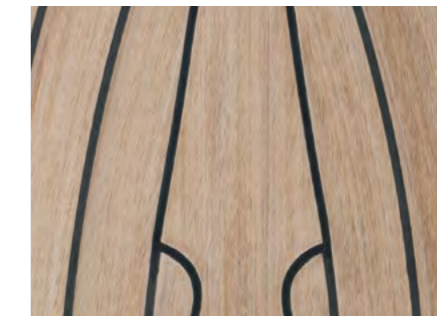

scrubbed look | black caulking

NATURAL TEAK OPTION

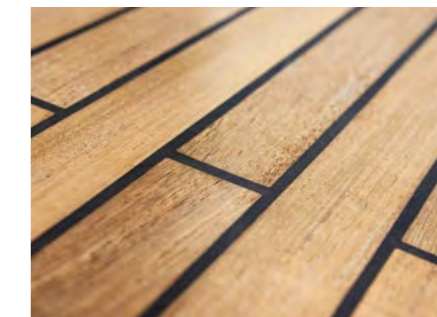

teak

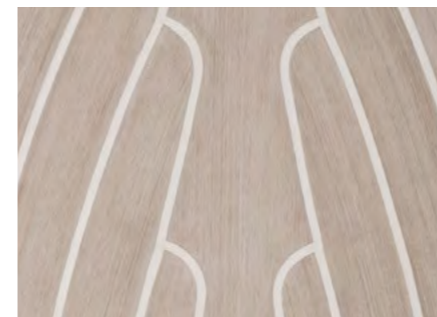

weathered look | white caulking

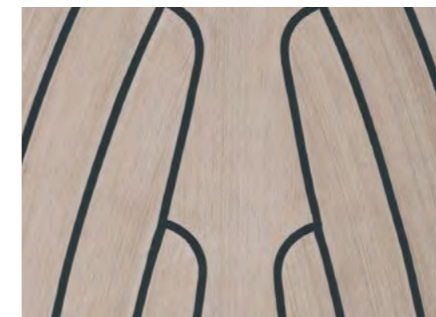

weathered look | black caulking

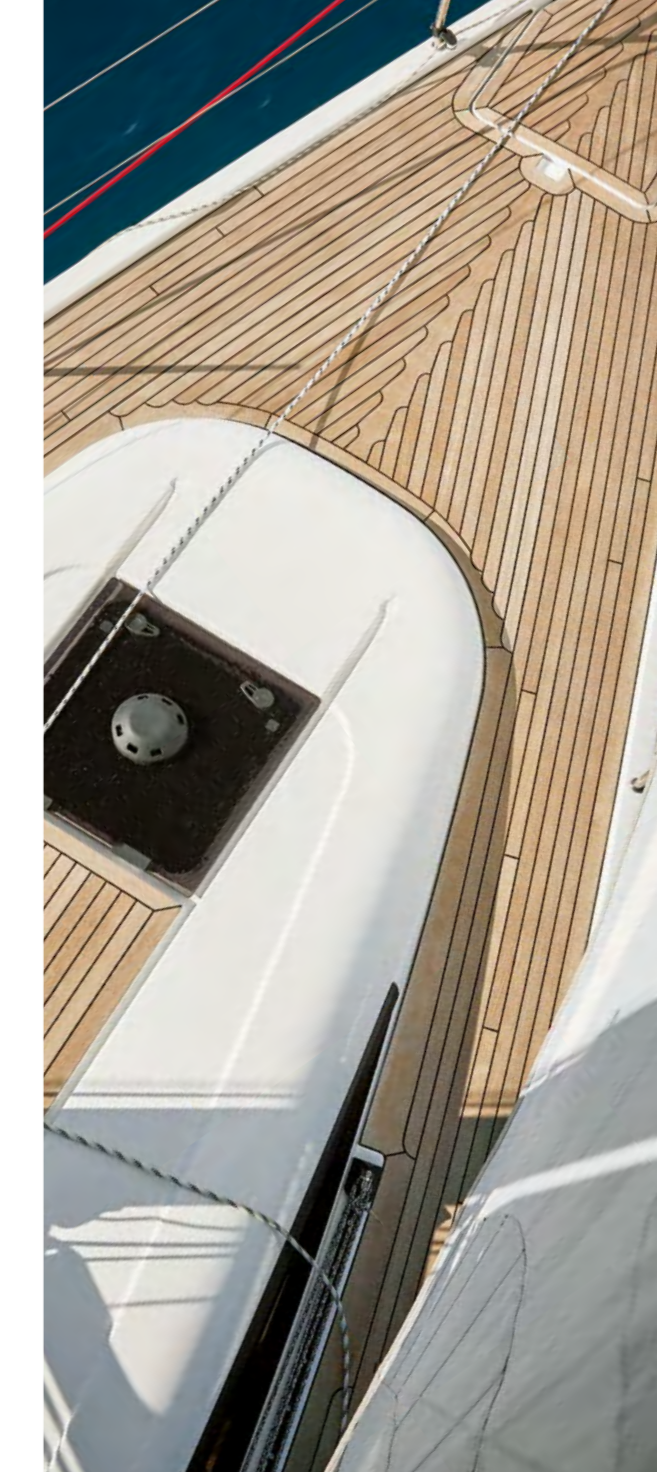



INTERIOR | UPHOLSTERY

FINEST MATERIALS TO SUIT YOUR TASTE

Mix and match as you wish. All interior upholstery can be matched with the following piping colours: gold, silver, red, blue and black.

PACIFIC OPTIONS



cliffside / blue piping



oyster / black piping



muscat / silver piping



graphite / gold piping

ADRIATIC LEATHER OPTIONS



ivory / blue piping



mud / black piping



clay / red piping



basalt / gold piping

INTERIOR | UPHOLSTERY

BALTIC STANDARD



cream / gold piping

ARCTIC OPTIONS



taupe / blue piping



silver / red piping



stone / silver piping



denim / gold piping

INTERIOR | SURFACES



WORKTOP GALLEY STANDARD

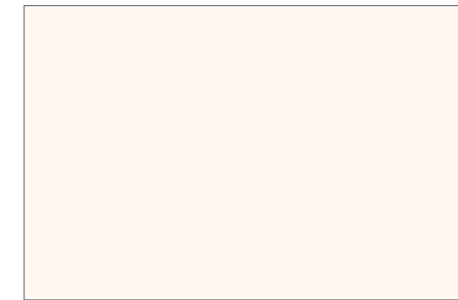

off white

OPTION



dark grey

FURNITURE WOOD STANDARD

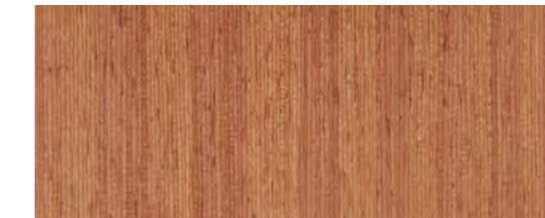

mahogany

OPTIONS



teak



oak

FLOORBOARDS STANDARD



australian acacia

OPTIONS

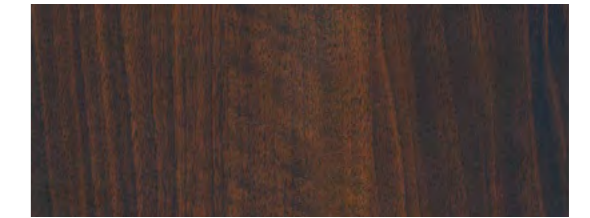

noce nero

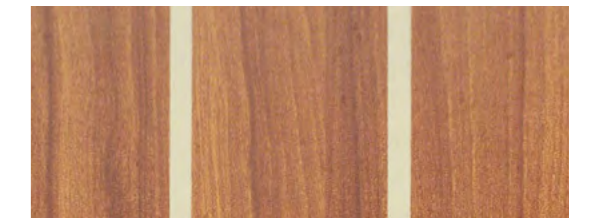

classic stripes

DEHLER CONNECT – BE SMART, BE INTELLIGENT AND UP TO DATE

MyDehler Safety Cloud

The MyDehler Safety Cloud enables real-time monitoring of your Dehler: anytime, anywhere, simply via the app. Protect your precious yacht remotely, as if you lived on board. You can organise maintenance and service with unprecedented ease. Thanks to the electronic logbook, a smartphone is all you need to share your sailing experiences with others. In short: this system will add a whole new dimension to your sailing passion.*

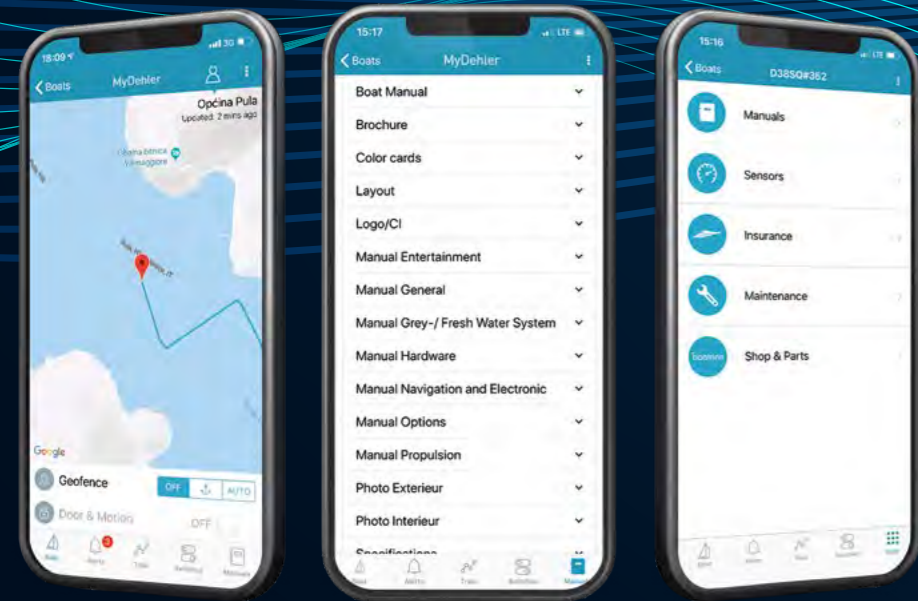

- 
Sensors
 Real-time monitoring of battery levels and devices.
- 
Maintenance
 Push notifications before due dates for maintenance of all components.
- 
Shop & Parts
 Feature for ordering equipment, supplies and spare parts.
- 
Manuals and operating instructions
 Manuals and operating instructions for all units and components on board.
- 
Insurance
 Exclusive in-app offers and conclusion of all insurances around the boat by Pantaenius.
- 
Switch Control
 Control of lighting and electrical devices (optional).
- 
Alerts
 Notifications for battery, bilge, shore power, anchor, geo fencing and more.
- 
Trips
 Electronic logbook with archive and share function for social media platforms.
- 
Report Issue
 Direct contact to the dealer.

MyDehler Sound Theatre

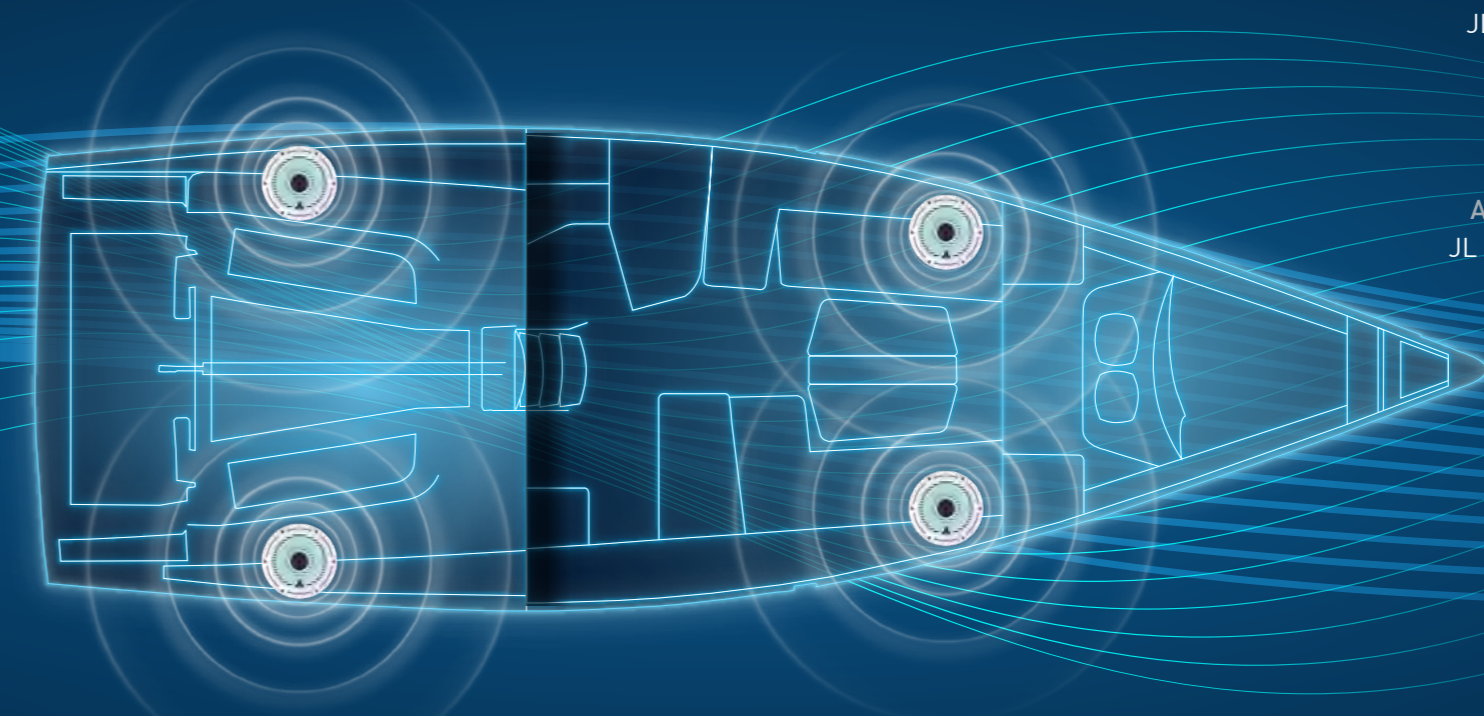

High-end sound meets high-class living
 Your first impression: brilliance. Even the finest acoustic nuances are brought out. Two pairs of loudspeakers – one in the cockpit, one in the saloon – overwhelm your ears with their outstanding clarity. Simplicity is the second thing you'll notice. We've brought the design and operation of the system back to the essentials, for intuitive control via the chart plotter or the separate control head. And thirdly, you'll enjoy the thrill of cutting-edge technology. The system is wireless, very compact and almost limitlessly flexible. This is the connectivity of the future.

JL Entertainment Package:

Remote
 JL Audio MMR-40



Audio Head Unit
 JL Audio MM 50 BE
 with bluetooth



Control via
 B&G Zeus³ 7"
 chartplotter



Speakers
 2 x 2 JL Audio
 speakers

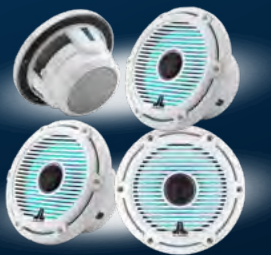

REFINE YOUR DEHLER WITH THE BEST



CRUISING

_ Hochwertige Ausstattungspakete für Ihre Dehler 385Q. Die vollständigen Bestandteile finden Sie in der Preisliste. Oder Sie sprechen Ihren Dehler Händler an.

_ Top quality equipment packages for your Dehler 385Q. You will find full details of each component in the price list. Or contact your Dehler dealer.

CRUISING PACKAGE

- | Teak on coach roof, cockpit bottom and bathing platform
- | Bathing platform, manual fold-out with swimming ladder
- | 2 additional cleats, midship, retractable (1 each side)
- | Anchor windlass, electrical with automatic fuse, remote control with chain counter
- | Delta-anchor 16kg, galvanised with 30m galvanised chain
- | 2 vents for coach roof hatches
- | MyDehler Safety Cloud with 24 months subscription and device installed on board
- | Battery set, capacity: 1x 90Ah + 2x 160Ah AGM
- | Blind set with flyscreens for hatches
- | Blinds for hull windows and side coach roof windows
- | Wind indicator
- | Flagpole
- | 6 fenders, 4 mooring lines, plaited
- | Dehler maintenance kit

UPGRADE | FLEXITEEK (colour selection)

- | Flexiteek on coach roof, cockpit bottom, cockpit benches and bathing platform

UPGRADE | STAINLESS STEEL ANCHOR WITH CHAIN

- | Delta-anchor 16kg, stainless steel, with 'Power Ball' swivel and 50m stainless steel chain
- | Upgrade – Battery set Lithium-ion
- | Battery set, capacity: 1x 90Ah + 3x 105Ah Li-ion batteries



COMPETITION

COMPETITION PACKAGE

- | Cove line – Competition
- | Rudder – Competition
- | 2 LEWMAR 45 Race Plus manual halyard winches
- | 2 LEWMAR 50 Race Plus manual secondary winches
- | 2 LEWMAR 50 Race Plus manual mainsheet winches
- | Genoa tracks (Competition), ball bearing sliders, adjustable from cockpit
- | Jib barber hauler with low-friction ring
- | Spinlock removable throttle

UPGRADE | ELECTRIC HALYARD WINCH

- | 2 LEWMAR 45 Race halyard winches, port: manual – stb: electric with automatic fuse

UPGRADE | COMPETITION KEEL

- | T-keel, cast iron/lead, (Competition) draught: 2.24m



NAVIGATION

B&G NAVIGATION PACKAGE | CRUISING

- | Instrument pod on helm station stb
- | 2 B&G Triton² multifunction displays, 1 per helm station, incl. transducer (wind/depth/speed/temperature)
- | B&G VHF V60 at chart table, incl. wireless remote handset H60
- | B&G Zeus³ 7" chartplotter, stb helm station
- | B&G Autopilot with Triton² control unit and Precision 9 compass
- | VHF preparation with antenna and splitter for FM and AIS

UPGRADE | COMPETITION

- | 2 B&G H5000 multifunction displays, 1 per helm station, incl. transducer (depth/speed/temperature) and wind sensor at vertical carbon mast head unit
- | B&G Autopilot with H5000 control unit and Precision 9 compass
- | B&G CPU Hydra computer (only with B&G H5000 instrument)

UPGRADE | SECOND CHARTPLOTTER

- | Instrument pod on helm station ps
- | B&G Zeus³ 7" chartplotter, ps helm station



GENNAKER

GENNAKER PACKAGE

- | QUANTUM Gennaker (colour selection)
- | Squeezer for Gennaker
- | Gennaker/Freeride package incl. halyard, 2 sheets, 2 blocks and padeyes

UPGRADE | COMPETITION GENNAKER

- | Competition composite bowsprit with integrated anchor fitting
- | QUANTUM Competition Gennaker (colour selection)



ENTERTAINMENT

JL ENTERTAINMENT PACKAGE

- | JL Audio MediaMaster 50 with bluetooth – for saloon and cockpit
- | 2x 2 JL Audio speakers in saloon and cockpit
- | JL Audio MMR-40 remote control



25936 YACHTS

have been delivered by Dehler since 1963 – an experience that results in excellence.

932 INNOVATIONS

that made sailing and living on board significantly more enjoyable were invented by Dehler.

65 MODELS

in all sizes up to 60 feet were created by our designers and developers.

58 YEARS

of yacht building have continuously increased the demands we place on ourselves and made us one of the leading sailing boat manufacturers.

1 PROMISE

follows from all that we've achieved so far:
To build our next Dehler 38SQ exactly as you desire it.

 [#dehleryachts](#)

Dehler **38 SQ**

Dehler Yachts

Ladebower Chaussee 11

D-17493 Greifswald

www.dehler.com

Design: www.smz.de | Print: Eggers Druckerei & Verlag GmbH | Photos: Nico Krauss, HanseYachts AG. This brochure is not contractual. The yachts depicted partly comprise special equipment not included in the standard scope of supply. Illustrations may not correspond with current versions. Subject to alterations in design and equipment without notice and errors excepted.

©2021 Dehler | CIBD38SQ/A/0321